

LIQUID - TURBINE FLOWMETER LMS - LWGY SERIES

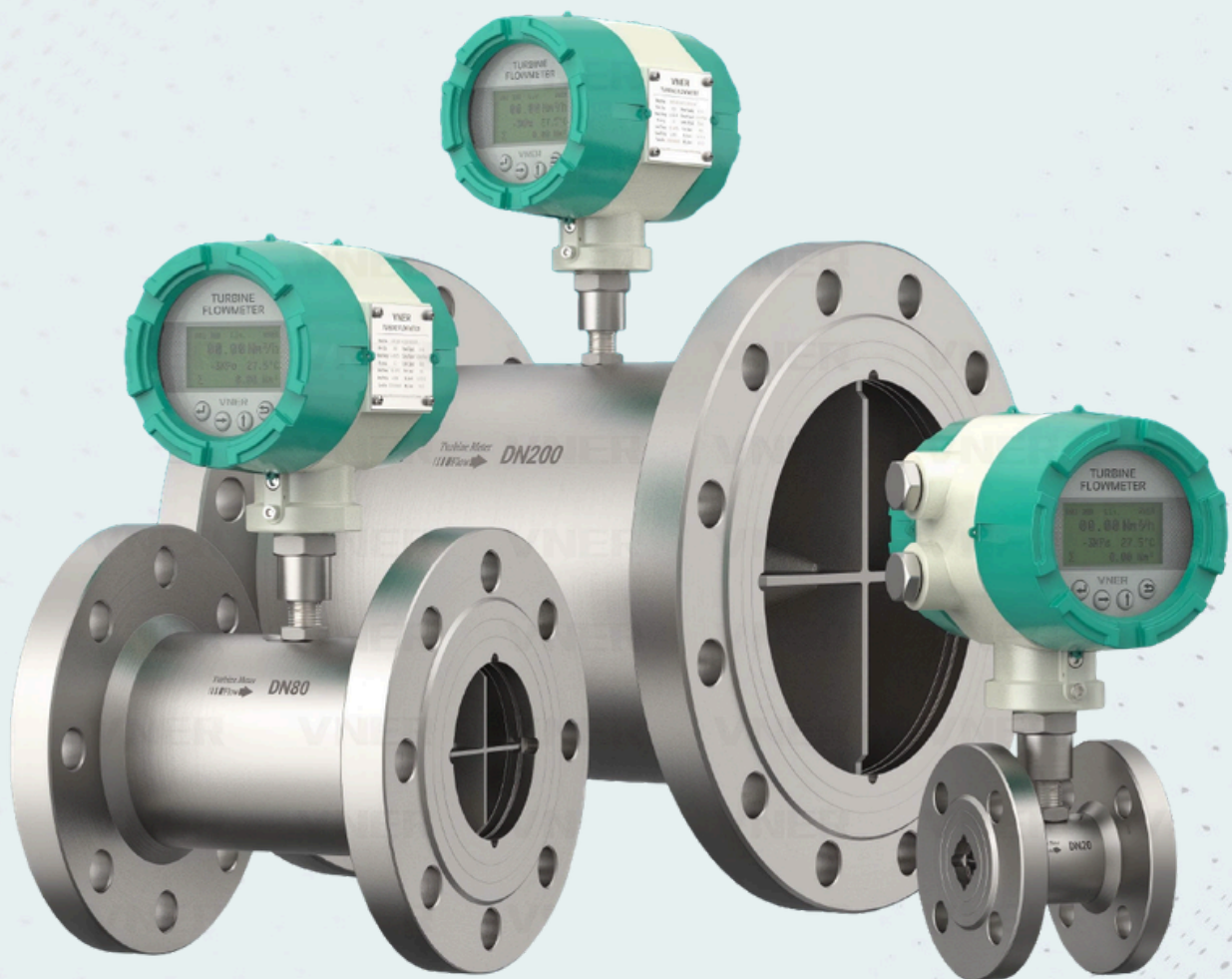

LOMAS

LOMAS LIQUID TURBINE FLOWMETER WORKING PRINCIPLE

The LMS - SA80T Enhanced Vortex flowmeter is a dependable device, designed with a simplified structure that is highly versatile and interchangeable. It utilizes digital NER signal processing, which enhances its anti-interference capabilities. The circuit module is assembled with components that meet higher reliability and durability standards, and the surface mount modular design eliminates low-reliability components such as potentiometers and plugs. This ensures that the flowmeter is highly stable and accurate.

1. Rotatable meter head
2. Anti-interference
3. Easy maintenance
4. Intelligent modular design



Rotatable Meter Tower



Removable Protection Covers



Easy-Maintenance Design



Eye-Catching Protection Paint



Digital & Intelligent modular structure

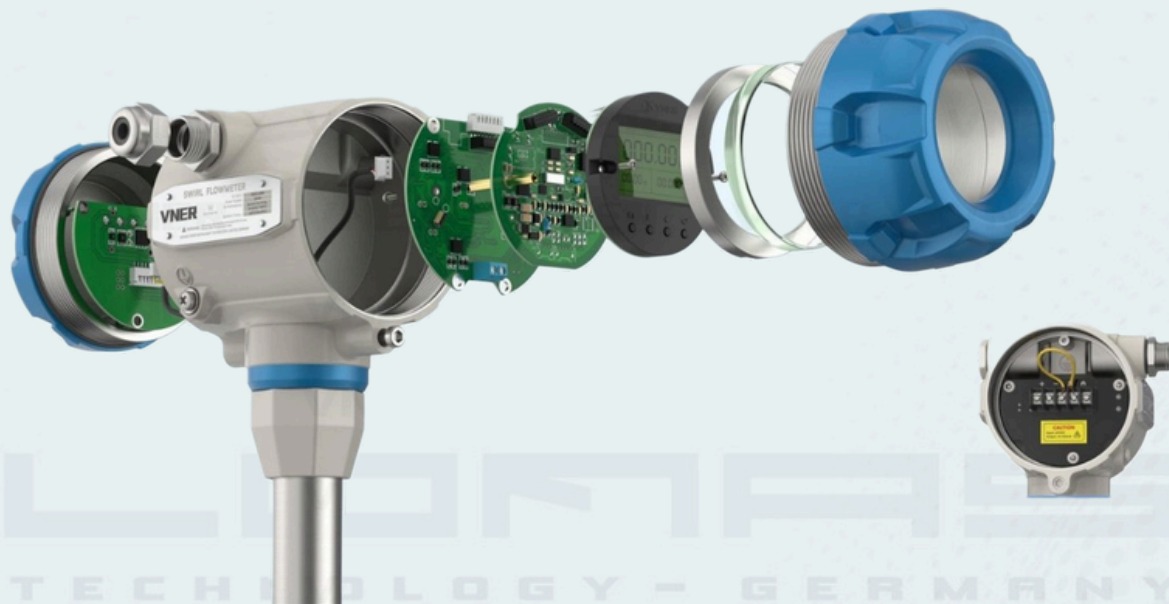

LMS - SA80T FLOWMETER OVERVIEW

The Vortex flowmeter is one of the major flow measurement instruments in the international market today. It is widely used in industrial sectors such as petroleum, chemical engineering, metallurgy, as well as in municipal construction and environmental protection projects. It measures, detects, and controls the flow of most liquids, gases, and steam. The LMS - SA80T vortex flowmeter is manufactured using the latest German technology and processes.

The product line includes the following variants with different functions:

1. The two-wire integral transmitter: Outputs a 4-20mA current signal and provides real-time display of instantaneous flow, cumulative flow, signal frequency, and output current value. It features low flow cut-off and fixed interference signal elimination functions.
2. Remote Type: Suitable for harsh environments such as high temperatures or high altitudes.

MAIN TECHNICAL PARAMETERS

The main technical parameters of the LMS - SA80T series are listed in the table below:

Applicable Medium	Gas. Liquid. Steam
Nominal Diameter (mm):	15, 20, 25, 32, 40, 50, 65, 80, 100, 125, 150, 200, 250, 300, 350, 400
Nominal Pressure (Mpa)	PN series. ANSI series
Medium Temperature	-40 to 250°C; custom configurations available for 350-400°C
Body Material	304, 316L stainless steel (other materials available by agreement)
Accuracy	Standard $\pm 1\%$, ($\pm 0.5\%$ available upon request)
Turndown Ratio	1:15 to 1:30
Output Signal	Transmitter: 4-20mA standard current signal proportional to flow
Power Supply	24VDC
Resistance Loss Coefficient	(Cd) <5
Explosion-Proof Marking	Exiall CT4-T6, Exdll CT4-T6
Ingress Protection	Standard type IP65, Submersible type IP67/1P68
Environmental Conditions	Ambient Temperature: -40 to +55°C Relative Humidity: 5% to 90% Atmospheric Pressure: 86% to 106Kpa

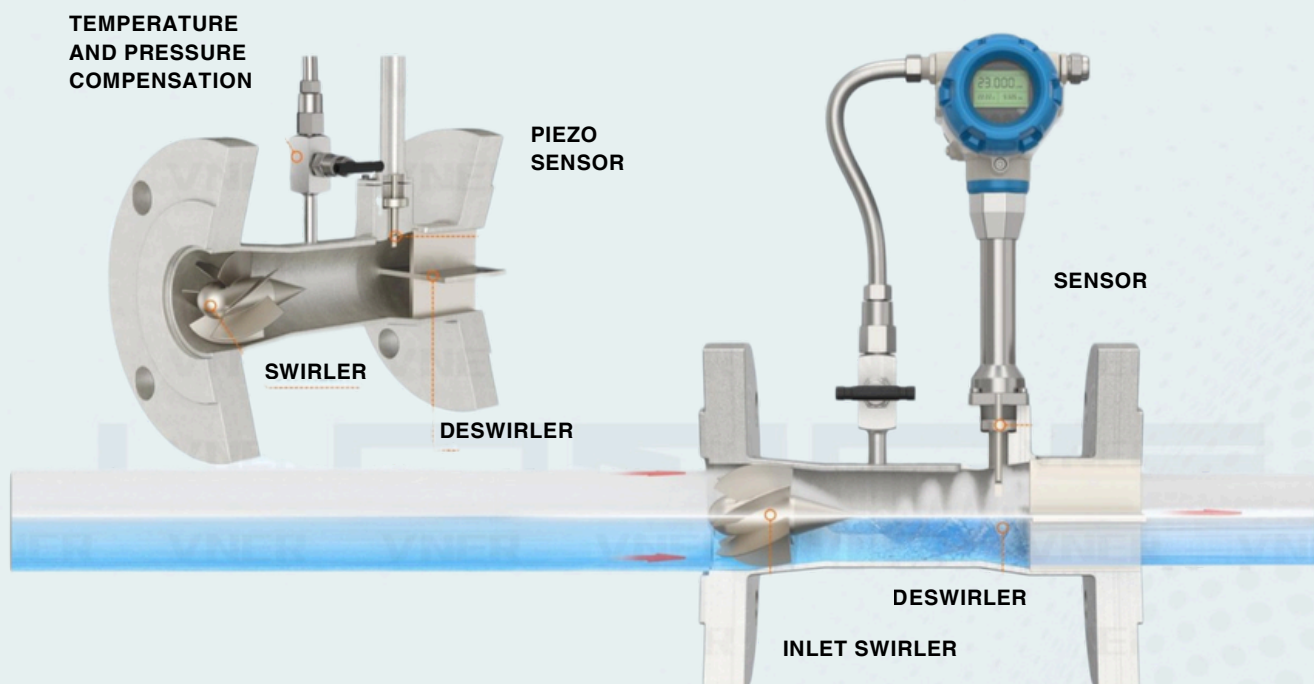

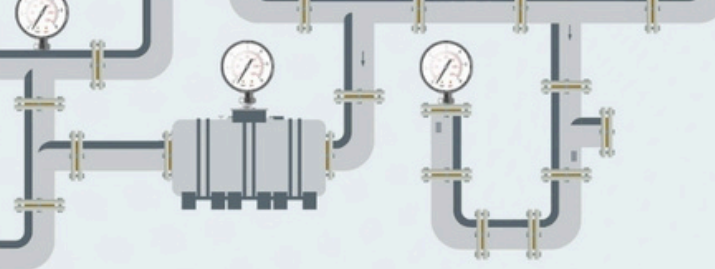

INSTRUMENT SERIAL CODE DESCRIPTION

VORTEX FLOWMETER					
Transmitter Type:					
Integral Model	E				
Remote model	R				
Submersible Model	C				
Digital Display and Power:					
On-Site LCD, 24 VDC System Power	D				
On-Site LCD, 3.6 VDC Battery Powered	B				
Process Connection Type:					
GB Flange		1			
DIN Flange		2			
ANSI Flange		3			
Measured Medium:					
Liquid			1		
Gas			2		
Saturated Steam, Overheated Steam < 350°C			3		
Body Material:					
Stainless Steel 304				A	
Stainless Steel 316L				B	
Carbon Steel				C	
Customization Available Upon Request				E	
Nominal Diameter:					
DN15				015	
DN20				020	
DN25				025	
DN32				032	
DN40				040	
DN50				050	
DN65				065	
DN80				080	
DN100				100	
DN125				125	
DN150				150	
DN200				200	
DN250				250	
DN300				300	
DN350				350	
DN400				400	
Nominal pressure:					
PN10					A
PN16					B
PN25					C
PN40					D
ANSI CLASS 150					F
ANSI CLASS 300					G

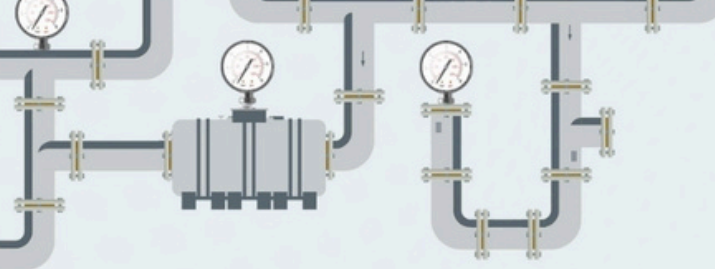

VORTEX FLOWMETER							
ANSI CLASS 600	H						
Customization Available (Max. 15MPa)	E						
Piezo Sensor Material:							
Stainless Steel 304	1						
Stainless Steel 316	2						
Hastelloy C	3						
Hastelloy B	4						
Titanium	5						
Sealing Material:							
Polytetrafluoroethylene (PTFE): (-40 to 150°C)	1						
Graphite O-Ring:(-200 to 280°C)	2						
Metal Wrapped	3						
Explosion Protection Certification:							
Without			A				
Explosion-Proof Exiall CT2-T6			B				
Explosion-Proof Exdll CT2-T6			G				
Nominal Calibration Type:							
Standard: Manufacturer Calibration				1			
Designated Third-Party Calibration				9			
Electrical Connection:							
M20x1.5					1		
1/2 NPT(F)					2		
Communication Protocol:							
Standard						A	
HART						H	
RS485						M	
Cryogenic Piezo Sensor:							
Temperature and Pressure Compensation:							
Temperature Compensation							Z
Pressure Compensation							-T
Temperature and Pressure Compensation							-P
Natural Gas Specific							-TP
							-NG
Additional Information:							
Device Identification Plate/Certification and Tag Plate Available On Request							
Display Glass Cover Depends On Request and Preference							
Operating Handle Customization Please Consult Manufacturer							
Specifications On Parts and Components Please Consult Manufacturer							

MEASURING RANGE FOR GAS AND LIQUID

GAS MEASURING RANGE

LOMAS LMS - SA80T VORTEX FLOWMETER GAS FLOW MEASURING RANGE (UNDER REFERENCE CONDITIONS)

Vales Based on Air: Temperature (t): 20°C/68°F; Pressure (p): 0.1013 MPa /14.7 Psi; Density (p): 1000 kg/m³/62.42 lb/ft³

Nominal Pipe Size (mm)	DN (mm)	ANSI Diameter	Min Flow (m ³ /h)	Max Flow (m ³ /h)
15	15	1/2"	1	15
20	20	3/4"	2	30
25	25	1"	3	50
32	32	1 1/4"	4	130
40	40	1 1/2"	7	200
50	50	2"	11	350
65	65	2 1/2"	15	650
80	80	3"	20	850
100	100	4"	30	1500
125	125	5"	45	2200
150	150	6"	70	3000
200	200	8"	120	5000
250	250	10"	180	7000
300	300	12"	250	10000
350	350	14"	350	14000
400	400	16"	450	21000

LIQUID MEASURING RANGE

LOMAS LMS - SA80T VORTEX FLOWMETER LIQUID MEASURING RANGE (UNDER REFERENCE CONDITIONS)

Values Based on Water: Temperature (t): 20°C/68°F; Pressure (p): 0.1013 MPa /14.7 Psi; Density (p): 1000 kg/m³/62.42 lb/ft³

Nominal Pipe Size (mm)	DN (mm)	ANSI Diameter	Min Flow (m ³ /h)	Max Flow (m ³ /h)
15	15	1/2"	15	15
20	20	3/4"	2	2
25	25	1"	4	6
32	32	1 1/4"	8	10
40	40	1 1/2"	16	16
50	50	2"	25	25
65	65	2 1/2"	35	60
80	80	3"	5	100
100	100	4"	75	150
125	125	5"	10	250
150	150	6"	18	370
200	200	8"	35	650
250	250	10"	60	800
300	300	12"	100	1100
350	350	14"	130	1300
400	400	16"	180	1800

INSTALLATION DIMENSIONS VORTEX FLOWMETER DIMENSIONS

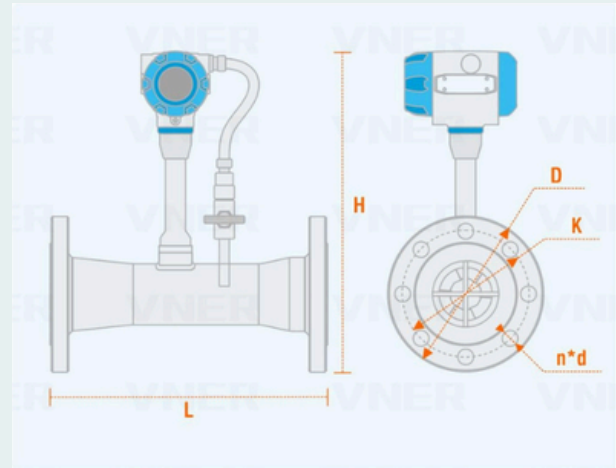
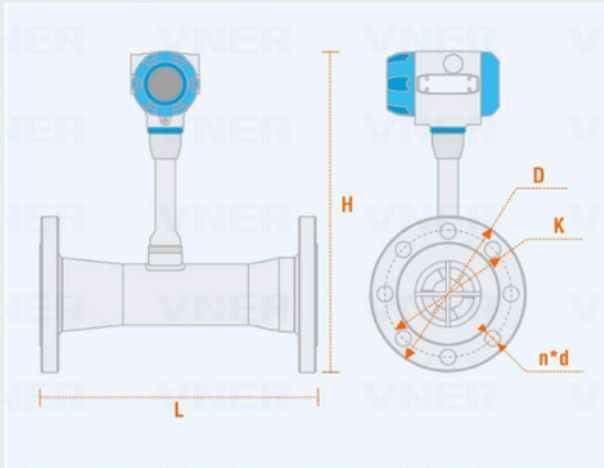

DIMENSIONS FOR DIN STANDARD

LMS - SA80T Swirl FlowMeter- PN 1.6 MPa

Dimensions for DIN standard flange

Nominal Diameter (mm)	Outer Diameter D (mm)	Bolt Hole Circle K (mm)	Bolt Hole Diameter L (mm)	Bolt Number	Thread Spec	Flange ID (mm)	Gasket Mount (mm)	Flange Thickness C (mm)	Flange Inner Dia B (mm)	Tube Length L (mm)	Weight (kg)
15	95	65	14	4	M12	45	2	14	225	200	2
20	105	75	14	4	M12	58	2	16	275	200	21
25	115	85	14	4	M16	68	2	16	345	200	34
32	140	100	18	4	M16	78	2	18	435	200	37
40	150	110	18	4	M16	88	2	18	495	250	68
50	165	125	18	4	M16	102	2	19	615	250	71
65	185	145	18	8	M16	122	2	20	775	300	9
80	200	160	18	8	M16	138	2	20	905	330	117
100	220	180	18	8	M16	158	2	22	116	410	17
125	250	210	18	8	M16	188	2	22	1.435	410	23
150	285	240	22	8	M20	212	2	24	1.705	580	29
200	340	295	22	12	M20	268	2	26	2.215	600	43
250	405	355	26	12	M24	320	2	29	2.765	800	105
300	460	410	26	12	M24	378	2	32	328	1000	173
350	520	470	26	16	M24	428	2	35	360	1100	209
400	580	525	40	16	M27	490	2	38	411	1270	247

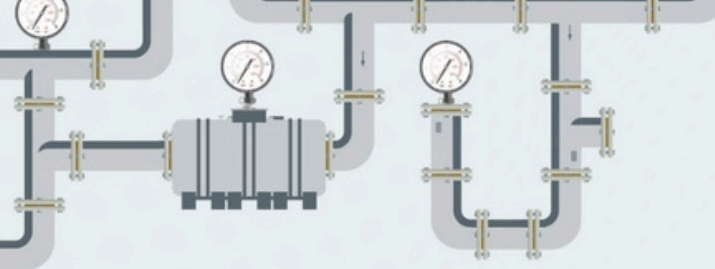

LMS - SA80T VORTEX FlowMeter- PN 2.5 MPa

Dimensions for DIN standard flange

DN (mm)	Outer D	Bolt Circle K	Bolt Hole L	Bolt		Flange ID	Gasket	Thickness C	Inner Dia B	Tube Length	Weight (kg)
				No	Thread						
15	95	65	14	4	M12	45	2	14	225	200	2
20	105	75	14	4	M12	58	2	16	275	200	21
25	115	85	14	4	M16	68	2	16	345	200	34
32	140	100	18	4	M16	78	2	18	435	200	37
40	150	110	18	4	M16	88	2	19	495	250	68
50	165	125	18	4	M16	102	2	20	615	250	71
65	185	145	18	8	M16	122	2	20	775	300	9
80	200	160	18	8	M16	138	2	21	905	330	117
100	220	180	18	8	M16	158	2	22	116	410	17
125	250	210	18	8	M16	188	2	22	1.435	410	23
150	285	240	22	8	M20	212	2	24	1.705	580	29
200	360	310	26	12	M24	274	2	32	222	600	59
250	425	370	30	12	M27	330	2	35	276	800	130
300	485	430	33	16	M27	389	2	38	328	1000	200
350	555	490	33	16	M30	448	2	42	384	1100	250
400	620	550	36	16	M33	513	2	46	430	1270	300

LMS - SA80T VORTEX FlowMeter- PN 4.0 MPa

Dimensions for DIN standard flange

DN (mm)	Outer (D)	Bolt Circle (K)	Bolt Hole (L)	Bolt		Flange ID	Gasket	Thickness C	Inner Dia B	Tube Length	Weight (kg)
				No	Thread						
15	95	65	14	4	M12	45	2	14	19	200	3
20	105	75	14	4	M12	58	2	16	26	200	32
25	115	85	14	4	M16	68	2	18	33	200	35
32	140	100	18	4	M16	78	2	18	39	200	47
40	150	110	18	4	M16	88	2	18	46	250	7
50	165	125	18	4	M16	102	2	20	59	250	72
65	185	145	18	8	M16	122	2	22	78	300	95
80	200	160	18	8	M16	138	2	24	91	330	12
100	235	190	22	8	M20	158	2	26	110	410	18
125	270	220	26	8	M24	188	2	28	135	410	26
150	300	250	26	8	M24	212	2	30	161	580	35
200	360	310	30	12	M27	268	2	36	222	600	66
250	425	370	33	12	M30	320	2	42	276	800	150
300	485	430	33	16	M30	378	2	48	328	1000	200
350	555	490	36	16	M33	428	2	55	380	1100	280
400	620	550	39	16	M36	470	2	60	430	1270	350

DIMENSIONS FOR ANSI STANDARD

LMS - SA80T VORTEX Flowmeter - Class 150 lbs (PN 2.0 MPa)

Dimensions for ANSI B16.5 standard

DN (mm)	ANSI Size (inch)	Outer D (mm)	Bolt Circle K (mm)	Bolt Hole L (mm)	Bolt		Sealing Gasket		Thickne ss C (mm)	Inner Dia B (mm)	Tube Length (mm)	Weight (kg)
					No	Thread	Flange ID	Mount (f)				
15	1/2"	90	603	16	4	M14	349	2	96	225	200	2
20	3/4"	100	699	16	4	M14	429	2	112	275	200	21
25	1"	110	794	16	4	M14	508	2	127	345	200	34
32	1 1/4"	115	889	16	4	M16	635	2	143	435	200	37
40	1 1/2"	125	984	16	4	M16	73	2	159	495	250	68
50	2"	150	1.207	18	4	M16	921	2	175	615	250	71
65	2 1/2"	180	1.397	18	4	M16	1.048	2	207	776	300	9
80	3"	190	1.524	18	4	M16	127	2	239	905	330	117
100	4"	230	1.905	18	8	M16	1.572	2	223	116	410	18
125	5"	255	2.159	22	8	M20	1.857	2	223	1.435	410	24
150	6"	280	2.413	22	8	M20	2.159	2	239	1.705	580	30
200	8"	345	2.985	22	8	M20	2.699	2	27	2.215	600	45
250	10"	405	362	26	12	M24	3.238	2	286	2.765	800	110
300	12"	485	4.318	26	12	M24	381	2	302	328	1000	182
350	14"	535	4.763	30	12	M27	4.128	2	334	360	1100	220
400	16"	595	5.398	30	16	M27	4.699	2	35	411	1270	260

LMS - SA80T VORTEX Flowmeter - Class 300 lbs (PN 5.0 MPa)

Dimensions for ANSI B16.5 standard

DN (mm)	ANSI Size (inch)	Outer D (mm)	Bolt Circle K (mm)	Bolt Hole L (mm)	Bolt		Sealing Gasket		Thickne ss C (mm)	Inner Dia B (mm)	Tube Length (L)	Weight (kg)
					No	Thread	Flange (mm)	Mount (f)				
15	1/2"	95	667	16	4	M14	349	2	127	225	200	3
20	3/4"	115	826	18	4	M16	429	2	143	275	200	32
25	1"	125	889	18	4	M16	508	2	159	345	200	36
32	1 1/4"	135	984	18	4	M16	635	2	175	435	200	54
40	1 1/2"	155	1.143	18	4	M16	73	2	191	495	250	89
50	2"	165	127	22	8	M20	921	2	207	615	250	98
65	2 1/2"	190	1.492	22	8	M20	1.048	2	239	776	300	13
80	3"	210	1.683	22	8	M20	127	2	27	905	330	162
100	4"	255	200	22	8	M20	1.572	2	302	116	410	275
125	5"	280	235	22	8	M20	1.857	2	334	1.435	410	36
150	6"	305	2.699	22	12	M24	2.159	2	35	1.705	580	46
200	8"	380	3.302	26	12	M24	2.699	2	397	2.215	600	75
250	10"	445	3.874	30	12	M27	3.238	2	461	2.765	800	120
300	12"	520	4.508	33	16	M30	381	2	493	328	1000	200
350	14"	585	5.144	33	16	M30	4.128	2	524	360	1100	280
400	16"	660	5.715	36	20	M33	4.699	2	566	411	1270	300

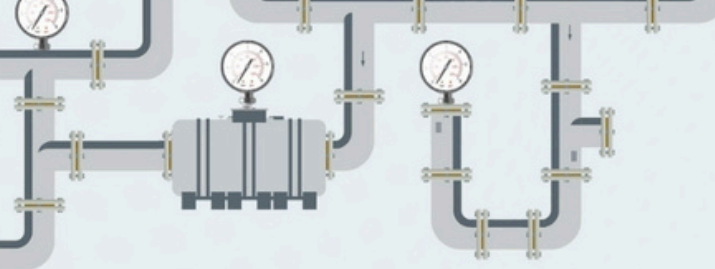

PRESSURE DROP FIGURE FOR GAS & LIQUID

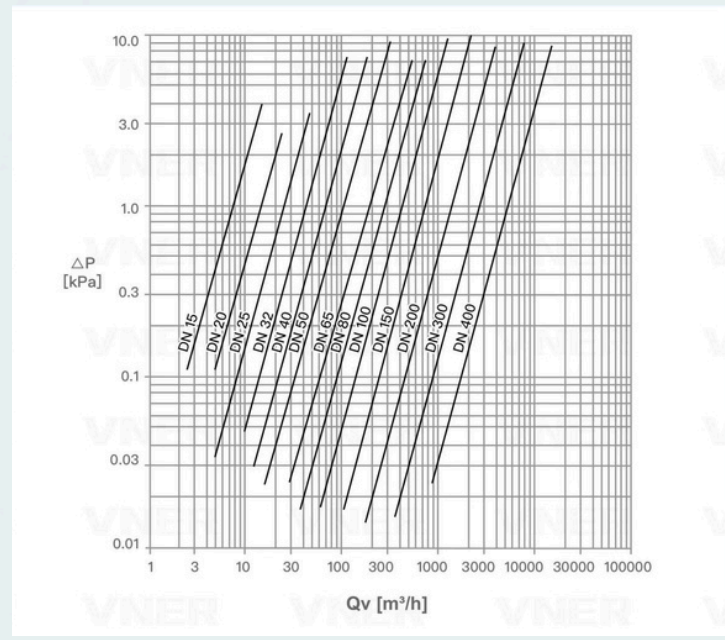

PRESSURE DROP FIGURE FOR GAS MEASUREMENT

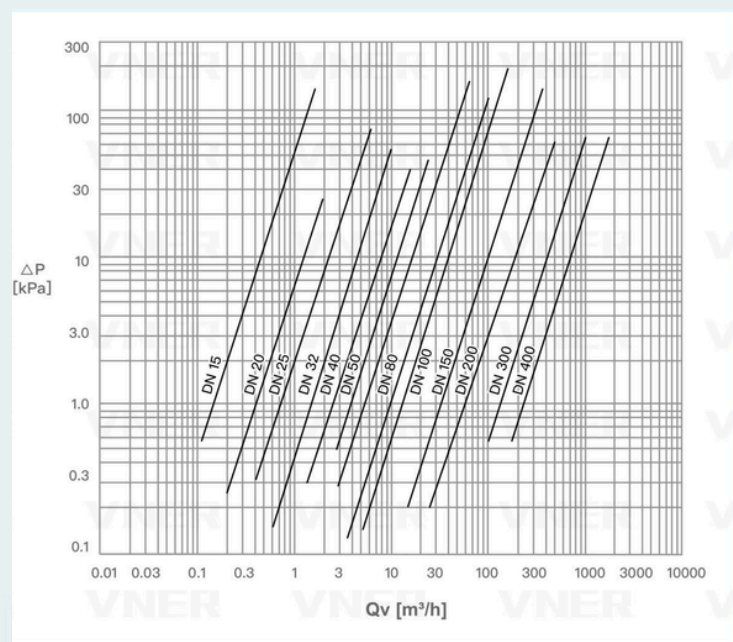

PRESSURE DROP FIGURE FOR LIQUID MEASUREMENT

PRESSURE DROP FIGURE FOR GAS & LIQUID

- The VORTEX flow meter can be installed indoors or outdoors. If installed in an underground well and there is a possibility of flooding, the submersible type should be selected.
- The VORTEX flow meter can be installed horizontally, vertically or inclined in the pipeline. When the measuring medium is liquid, then the pipe must be filled with liquid. Therefore, when installing VORTEX flow meter on vertical or inclined pipeline, the flow direction of liquid should be from bottom to top.
- VORTEX flowmeter does not require a long straight pipe section, and the required length of the upper and lower straight pipe sections depends on the condition of the pipe. The upper end of the VORTEX flow meter should avoid installing a regulator or half-open valve as much as possible, and should be installed 5D after the lower end of the flow meter.
- In the design of the pipeline installation, the upper end of the flowmeter signal converter should be left 500mm space, to facilitate commissioning and maintenance.
- When the flowmeter requires a temperature-pressure compensation type, the pressure transmitter is installed at (1-2) D downstream of the flowmeter, and the temperature measuring element (usually with platinum resistance) is installed downstream (3-5) D.

GENERAL UPSTREAM AND DOWNSTREAM PIPE SECTIONS

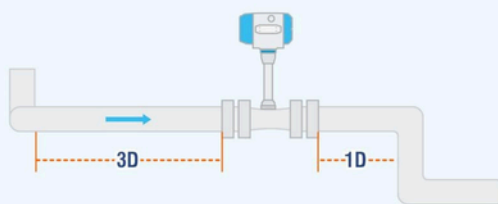

TWO 90° ELBOWS ON DIFFERENT PLANES

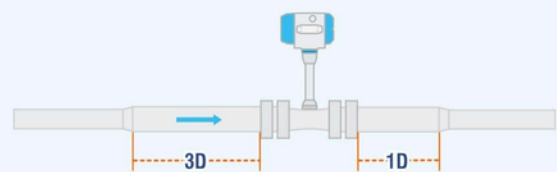

CONCENTRIC FLARED TUBE

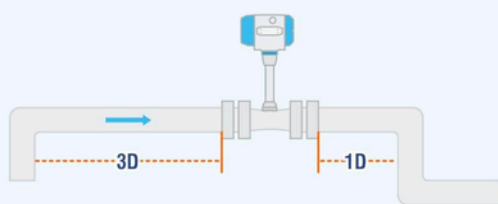

ONE 90° ELBOW

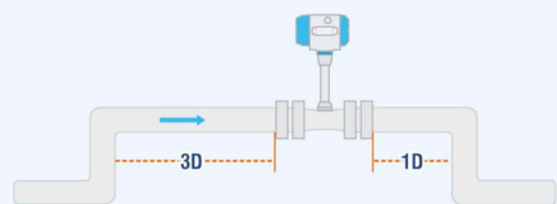

TWO 90° ELBOWS ON ONE PLANE

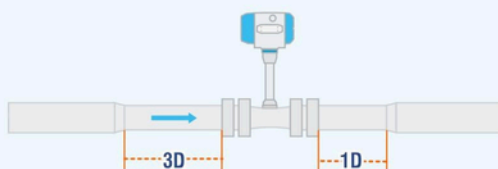

CONCENTRIC CONTRACTIVE FULL-OPEN VALVE

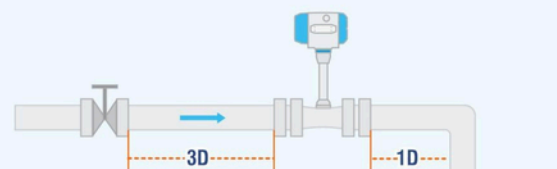

HALF-OPENED ADJUSTMENT VALVE

INSTALLATION POSITIONING

1. The flowmeter can be installed indoors or outdoors, with an ambient temperature range of -20°C to $+55^{\circ}\text{C}$. LOMAS
2. When the temperature of the measured medium exceeds 150°C , the display head can be installed horizontally or vertically downward (see Figure 1). Alternatively, a remote type can be selected, which is also suitable for harsh environments such as high altitudes or underground (see Figure 2). The maximum extension distance is 10 meters.

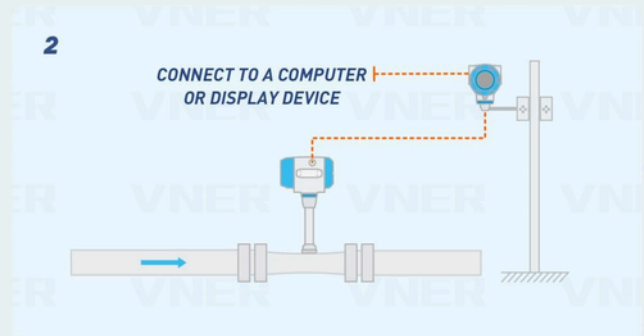
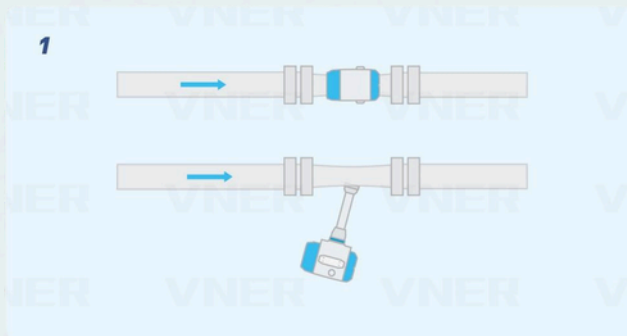

3. When measuring liquids and the flowmeter is installed on a vertical or inclined pipeline, the liquid flow direction should be from bottom to top (see Figure 3).

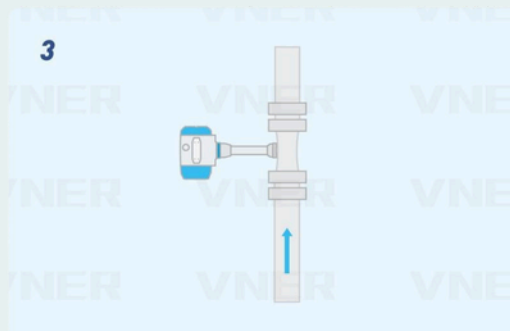

4. To facilitate commissioning, disassembly, and on-site maintenance of the flowmeter, there should be at least 0.5 meters of clear space above the display head (see Figure 4). If this cannot be ensured, the installation angle should be adjusted during installation.
5. It is advisable to avoid installing control valves or partially open valves upstream of the flowmeter. If required by the process, they can be installed downstream of the flowmeter at a distance of $5D$ (see Figure 5).

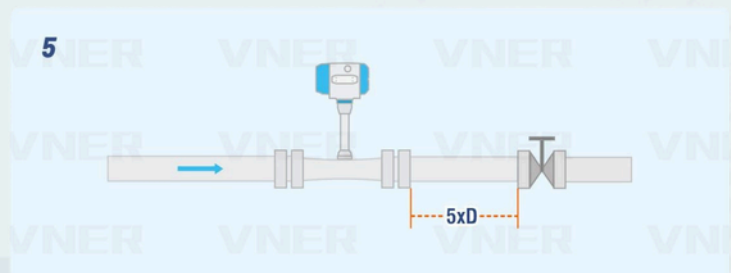
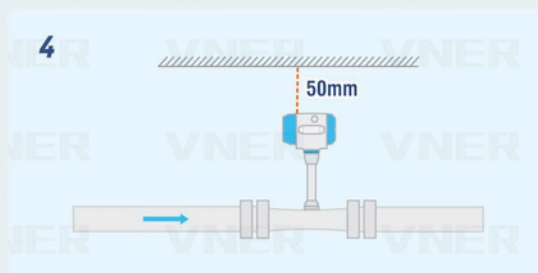

6. Signal Transmission Distance: The maximum transmission distance for the current output signal is 800 meters.
7. If the swirl flowmeter is installed on a pipeline with significant vibration, a flexible connection pipe should be added, or the pipeline should be secured (see Figure 6)

6

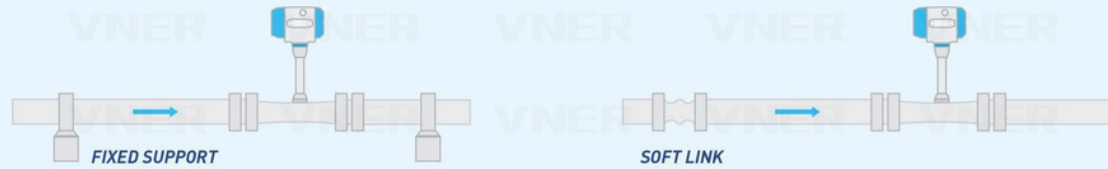

8. When measuring gas or steam, the swirl flowmeter should be installed at a high point in the pipeline to avoid condensate accumulating in low points. If installed at a low point, a drain valve should be added. When measuring liquids, the flowmeter should be installed at a low point in the pipeline to ensure full-pipe measurement.

9. Sufficient straight pipe sections should be reserved upstream and downstream of the flowmeter. The recommended lengths of the straight pipe sections are shown in Figure 7. D is the nominal diameter of the instrument in mm

7

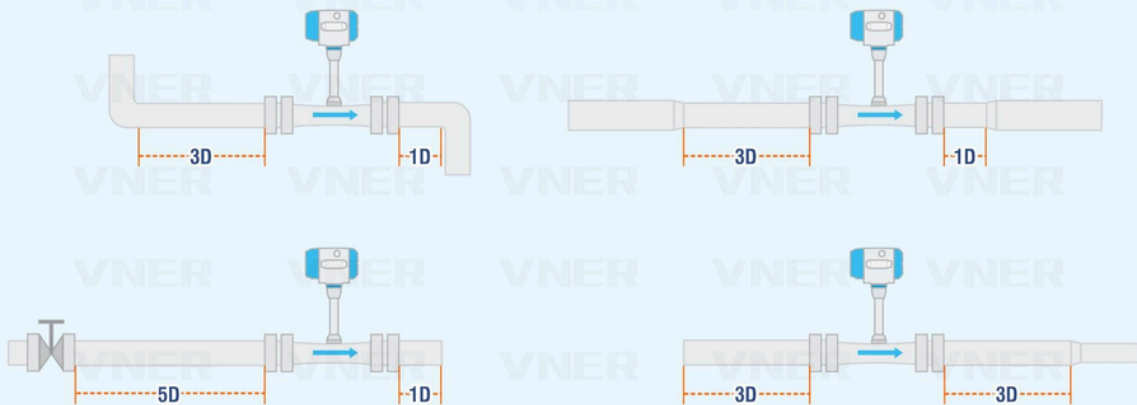

INSTALLATION FOR EXTERNAL TEMPERATURE AND PRESSURE MEASUREMENT

8

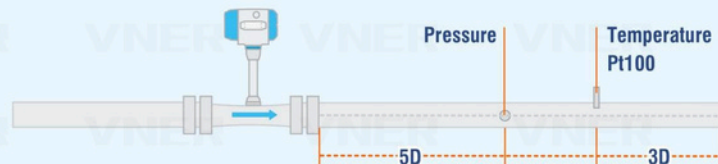

1. The temperature sensor (PT100) should be installed by drilling a hole ($\varnothing 25$ diameter) 5D downstream of the flowmeter. Weld the base in place and tighten the temperature sensor.
2. The pressure transmitter should take pressure from the pressure tapping point (1/4" NPT) on the lower side of the flowmeter or from a point 3D downstream of the flowmeter.

ISSUES TO NOTE DURING INSTALLATION:

1. Pay attention to the flow direction arrow on the flowmeter body; it should be aligned with the direction of the medium flow.
2. The inner diameter of the gaskets on both sides of the flowmeter should not be smaller than the inner diameter of the flowmeter body.
3. Pay special attention to the alignment of the flanged flowmeter with the pipeline.
4. During flange welding, the flowmeter should be removed to avoid damaging the sensor probe due to excessive welding temperatures.